

Operating instructions

# Gate Valve

Type 2004/4004 with rotatable flanges  
for water

Item no. of the operating instructions: 764836, issue 04, 12 pages  
Specifications subject to change without notice



**for hand wheel, stem extension set, with electric actuator, chain wheel or operating key**

## **1. Intended use**

## **2. Safety precautions**

2.1. General safety instructions

2.2. User safety instructions

2.3. Special risks

## **3. Transport and storage**

## **4. Installation into the pipeline**

4.1 Installation of rotatable flanges

## **5. Operation**

## **6. Actuators**

## **7. Inspection and Maintenance**

## **8. Drawing and parts list**

8.1. Drawing and parts list for gate valve with handwheel, stem extension set, chain wheel and operating key

8.2. Drawings and parts list for gate valve with electric actuator

## **9. Diagnostics and trouble shooting**

## 1. Intended Use

After the installation into a pipe system, shut-off valves are only intended for stopping or allowing media to pass within the range of the permitted operating conditions (temperature and pressure limit "PN" labeling on the valve, unless stated otherwise).

Gate valves are used exclusively for open/closed operation in pipe systems.

These valves are preferably intended for liquid media, such as drinking water. Any deviating operating conditions or areas of application are subject to manufacturer approval.

We will not assume any responsibility for consequential damage caused by

- unauthorised modification of the valve and the accessories supplied
- improper operating or operating conditions
- acts of God



Continuous operation of the valve in an intermediate position will lead to increased wear of the gate valve or the subsequent pipe system up to total destruction and should therefore be avoided.

Cavitation can be identified among other things by:

- Increased noise level
- Crackling noise
- Severe vibrations

Cavitation can be avoided by operating the valve only in fully OPENED or fully CLOSED position.

## 2. Safety Precautions

### 2.1. General safety instructions

The same safety regulations apply for valves as for the pipe system in which they are installed. The following instructions only include additional safety instructions to be observed for valves.

When using this valve, the generally recognized rules of good practice (standards, DVGW regulations W332 and W392, VDI guidelines or other regulations valid at the place of installation) must be observed.

## 2.2. User safety instructions

The operator of the valve must ensure that the valve is only used in accordance with the intended use. This is not the responsibility of the manufacturer. The valve may only be operated by properly qualified and trained staff. The operating manual and the corresponding safety instructions must be read and understood.



It is prohibited to use any valves with a nominal pressure ("PN") and maximum admissible operating temperature insufficient for the operating conditions. The approved range is indicated on the valve.



Warning: Temperatures below 10 °C and above 40° C during work on the pipeline parts involve the risk of injury. Protective measures must be taken accordingly.



Operating media must correspond to the specification of the valve. The manufacturer does not assume any liability for damage resulting from corrosion caused by aggressive media. Neglect of these regulations may result in imminent danger to life and health, and may cause damage to the pipeline.

- The valve must be professionally installed into the pipeline.
- Following EN 1074-1, the maximum flow velocity may not surpass 4 m/s in continuous operation.
- Operating conditions such as vibrations, water impact, erosion, cavitation and major proportions of solid matter in the medium - especially of an abrasive nature – must be clarified with the manufacturer prior to commissioning.

## 2.3. Special risks



Be sure to free the pipeline from any pressure and risk prior to disassembly, maintenance and repair of the valve. During disassembly the medium may leak, therefore the pipeline and the valve must be completely emptied. The energy supply must be switched off.

### 3. Transport and storage

All valves must be carefully transported and stored.



The valves are fully enameled or powder-coated. The coatings are shock-sensitive and must be protected against impact stress.



The gaskets are sensitive to light: Unpackaged valves may only be exposed to bright daylight or ultraviolet light for a very short time. This is why the openings are sealed with protective caps. Valves must be stored in darkened rooms, in their original packaging with the protective caps.



In the event of storage over an extended period of time, the storage location should be frost-protected, cool, dry, dark and free of dust. Alternatively, the valves may also be packed in order to fulfill these conditions.

The valve should be stored on a pallet or similar support and only transported with suitable tools such as wide straps to its designated point of installation. Do not use chains!

### 4. Installation into the pipeline

For the installation of valves into pipe systems, the same instructions apply as for the connection of pipe system components. The DVGW regulation W 400-2 must be observed.



The valve with rotatable flanges is not suitable for end of line applications.



The loose flanges have a limited sliding tolerance (+ 8mm). In addition, they are tightly connected to the valve housing guaranteeing tensile strength. The construction length is manufactured closer to the minus tolerance. Additional allowance for clearance is caused through the elimination of the flange gaskets on the loose flange sides. The gasket is integrated in the loose flange.

The following work steps must be observed:

- Transport the valve to the point of installation in its protective packaging.
- Remove all packaging materials from the valve.
- Check valve for transportation damage. Damaged valves must not be installed.
- Check coating for damages. The coating may be mended with a repair kit.
- It needs to be ensured that nominal pressure and connecting dimensions of the valves are in correspondence with the operating conditions. See marking on the valve.
- Remove dirt and hard foreign matter from valves and pipelines prior to installation.
- A functional test must be carried out prior to installation: The valve must shut and open properly.
- The connections of the pipeline must be adjusted concentric and with flanges plane parallel to the valve.

- When inserting the valve and the gaskets into a pipe already mounted, the gap between the pipe ends must be large enough, so that none of the connecting faces and gaskets are damaged. The gap should not be larger than absolutely necessary so as not to create any additional tension inside the pipe during installation.
- The valve is to be installed without tension.
- Shut- off valves may be installed in any installation position independent of the flow direction.



Exceptions:

For gate valves with electric actuator we recommend the installation position in a horizontal pipe system with vertical stem pointing upwards.



**Loose flanges must be locked.**

- The connecting bolts with washers must be tightened evenly and crosswise.
- When using detergents and disinfectants it must be ensured that these products do not attack the materials and gaskets of the valve.
- Newly installed pipe systems must be flushed thoroughly in order to remove all foreign particles. Observe the DVGW worksheets W 291 and W 346.
- During the pressure test of the pipe system with the installed valve, the following test pressures may not be surpassed:



Valve opened: The test pressure must not exceed 1.5 x PN (see type plate).  
Valve shut: The test pressure must not exceed 1.1 x PN (see type plate).

- The valve must be protected from dirt which can derive from work (e.g. painting, masonry and concrete work) in the area of the valve.

## 4.1 Installation of rotatable flanges

horizontal marking: Loose flange can be slid over the lock

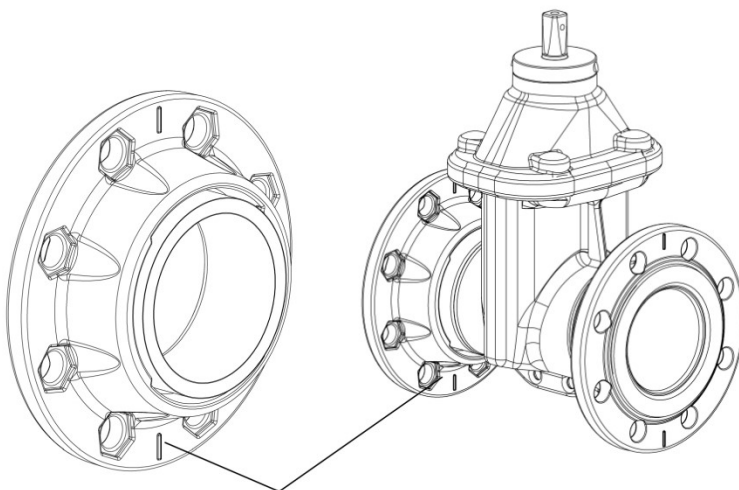
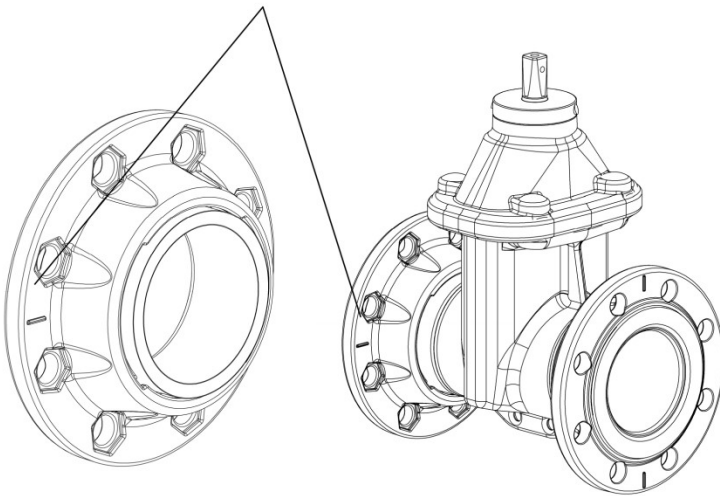

vertical marking- Loose flange is locked



## 5. Operation

The valve is shut by turning it clockwise and is opened by turning it in the opposite direction. Manual power suffices to operate the valves. Use of extensions to increase actuating torque is not permissible, since this will cause damage to the valve.

nominal diameter	max. operating torque as per EN 1074-2	no. of turns for closing	stem square
DN	MOT Nm		mm
80	80	16	17
100	100	20	19
125	125	25	19
150	150	30	19
200	200	34	24

### Operating torques

The stated operating torques are the maximum permissible torques for full differential pressure at the actuating stem, these are described in EN 1074-2.

## 6. Actuators

Actuators (hand wheel, operating keys, chain wheel, stem extension sets and electric actuator) are designed for flow velocities as described in paragraph 2.2.

For detailed information on the electric actuators please consult the operating manuals of the manufacturer.



If these regulations are not observed, this can result in jeopardy for life and limb and cause damages in the pipe system.

When demounting electrical actuators from a valve, the safety regulations as per chapter 2 must be observed, and the electrical power supply must be switched off.

### Gate valve with electric actuator

The electric actuator is mounted onto the top flange. The actuator dimensioning was selected in correspondence with the maximum operating torques.

The valve is switched off:

- in open position path-dependent
- in closed position torque-dependent



The path and torque switches of the actuator are adjusted in the factory. The path switch for the closed position only serves as a signal transmitter. The torque switch serves as an overload protection in in-between positions, see also the operating manuals of the manufacturer of the actuator. If the valve is equipped with an electric actuator on site, the path and torque switches must be adjusted after mounting. We recommend calling our service technician if a valve is equipped with an actuator on site.



Observe the safety regulations of VDI/VDE or other regulations for electric installations valid at the place of installation as well as the regulations of the manufacturer of the electric actuator.

## 7. Inspection and Maintenance

The valves do not require regular maintenance work. However, when a pipeline section is inspected, the valve may not show any leakage to the outside.

The valve should be checked for tightness and, proper function at least once per year (DVGW datasheet W 392-2 and W 400-3-B1).

## 8. Drawing and parts list

### 8.1. Drawing and parts list for gate valve with hand wheel, stem extension set, chain wheel and operating key

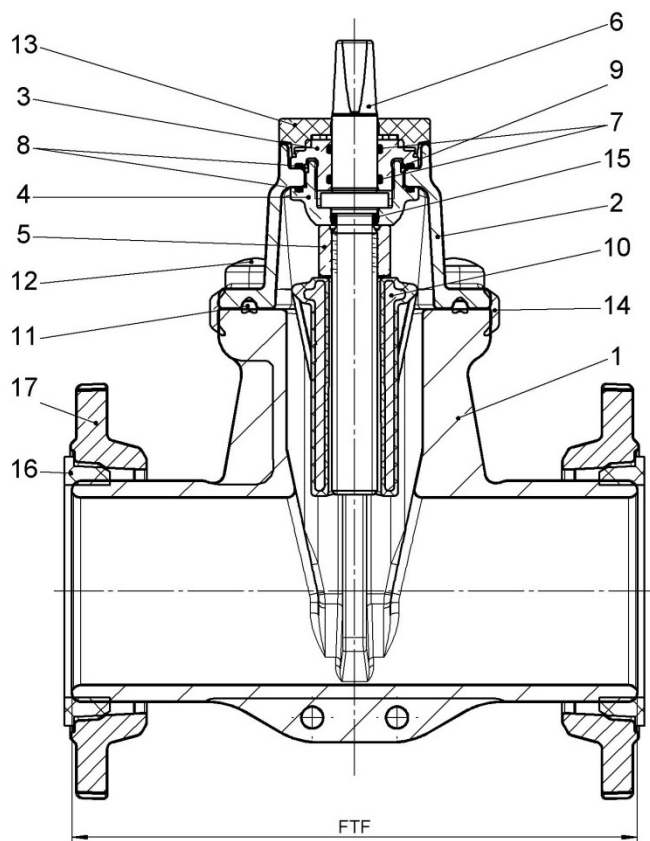

Pos	Description
1	body
2	bonnet
3	cap nut
4	clamp piece
5	stem nut
6	stem
7	O-ring
8	O-ring
9	snap ring
10	wedge
11	head gasket
12	cylinder screw
13	cover cap
14	bonnet edge protector
15	O-ring
16	gasket LKS
17	loose flange

All spare parts are available as a complete package "bonnet with stem", except Pos. 1, 14, 16 and 17.

#### Face-to-face dimensions type 4004 basic series 15:

DN	FTF + 8 mm
80	280
100	300
125	325
150	350
200	400

#### face-to-face dimensions type 2004 basic series 14:

DN	FTF + 8 mm
80	180
100	190
125	200
150	210
200	230

## 8.2 Drawing and part list for gate valve with electric actuator

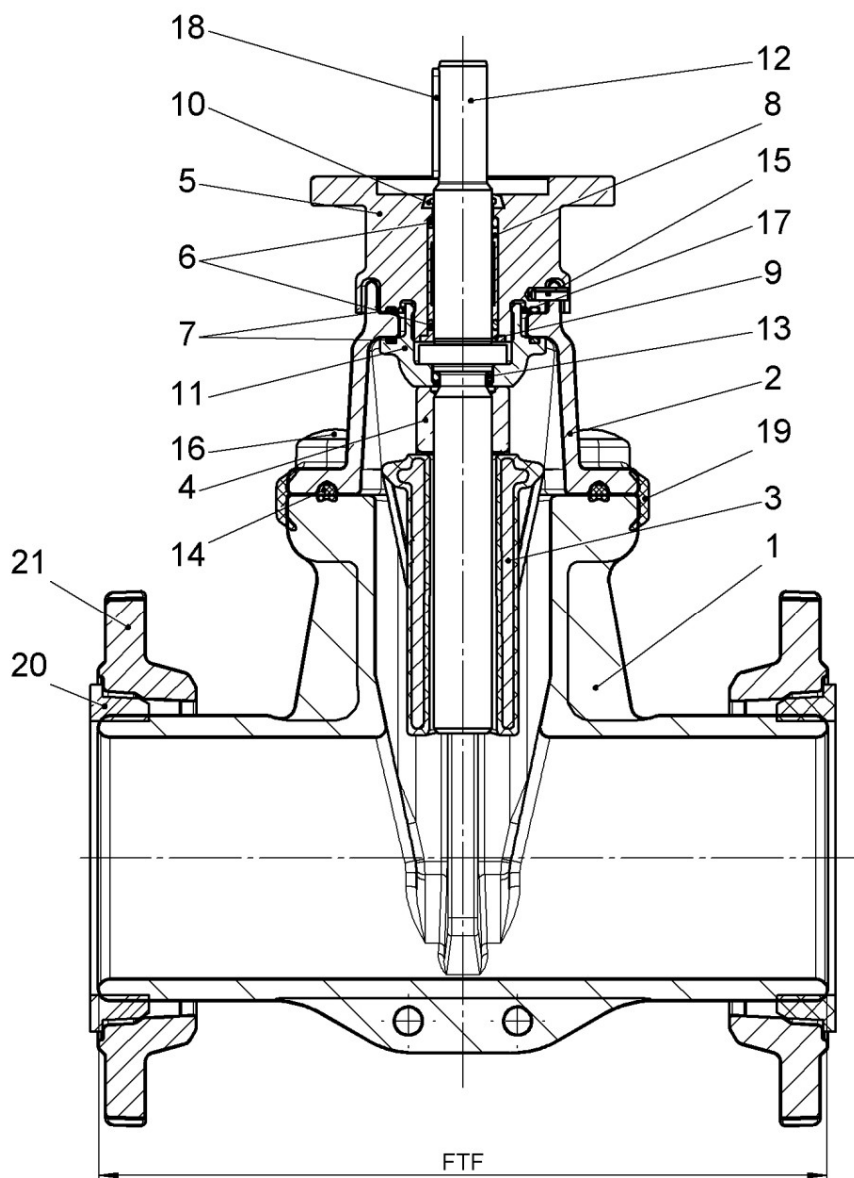

Pos	Description
1	body
2	bonnet
3	wedge
4	stem nut
5	mounting flange
6	O-ring
7	O-ring
8	bush
9	collar bush
10	screening ring
11	clamping piece
12	stem
13	O-ring
14	head gasket
15	grooved cylindrical pin
16	cylinder screw
17	snap ring
18	feather key
19	bonnet edge protector
20	gasket LKS
21	loose flange

All spare parts are available as a complete package "bonnet with stem", except Pos. 1, 19, 20 and 21.

## 9. Diagnostics and trouble shooting

Problem	Possible cause	Remedial action
Gate valve does not close	Foreign particle on sealing face	Remove foreign particle
	Heavy deposits on the sliding surface	Clean sliding surface
Gate valve does not open	Foreign particle is jamming sealing wedge	Remove foreign particle

### Leakage at the connection to the head flange:

- Retighten flange screws.
- If the leakage continues: Repair necessary.
- Replace the bonnet unit with sealing wedge and head gasket following consultation with the manufacturer. Retighten flange screws crosswise and step by step up to a torque of max. 60 Nm. Then protect the bolt heads with acrylic sealing mass.

### Leakage at the stem or seat gasket:

- Check whether the valve is completely shut.
- If so: Verify whether the valve has been shut with the full torque.
- If leakage on the valve continues: Open and shut the valve several times while under pressure.
- If the leakage on the valve continues: Repair necessary.
- Replace the bonnet unit with sealing wedge and head gasket following consultation with the manufacturer. Retighten flange screws crosswise and step by step up to a torque of max. 60 Nm. Then protect the bolt heads with acrylic sealing mass.



We would like to point out that we do not assume any liability for damages or disruption of operations resulting from non- observance of the operating manual.

**To ensure the function and compliance with the drinking water hygiene standards, only original Düker original spare parts may be installed.**

The distribution and reproduction of these Operating Instructions, utilization and communication of their contents to others is authorized exclusively for the purpose of ensuring the correct installation and operation of the Düker product treated in the document. For all other purposes, distribution, reproduction and utilization of the contents, also in excerpts, is prohibited. Offenders will be held liable for the payment of damages. All rights reserved in the event of the grant of a patent, utility model or design.