

Operating instructions

Service connection valves

Type 1004 with flange and PE welding stud
for gas/water

Item no. of the operating instructions: 317845 issue 02, 9 pages

Specifications subject to change without notice



for hand wheel and stem extension set

1. Intended use

2. Safety precautions

2.1. General safety instructions

2.2. User safety instructions

2.3. Special risks

3. Transport and storage

4. Installation into the pipeline

5. Operation

6. Actuators

7. Inspection and Maintenance

8. Drawing and parts list

9. Diagnostics and trouble shooting

1. Intended Use

After the installation into a pipe system, shut-off valves are only intended for stopping or allowing media to pass within the range of the permitted operating conditions (temperature and pressure limit "PN" labeling on the valve, unless stated otherwise).

Gate valves are used exclusively for open/closed operation in pipe systems.

These valves are preferably intended for liquid media, such as drinking water or gas. Any deviating operating conditions or areas of application are subject to manufacturer approval.

We will not assume any responsibility for consequential damage caused by

- unauthorised modification of the valve and the accessories supplied
- improper operating or operating conditions
- acts of God



Continuous operation of the valve in an intermediate position will lead to increased wear of the gate valve or the subsequent pipe system up to total destruction and should therefore be avoided.

Cavitation can be identified among other things by:

- Increased noise level
- Crackling noise
- Severe vibrations

Cavitation can be avoided by operating the valve only in fully OPENED or fully CLOSED position.

2. Safety Precautions

2.1. General safety instructions

The same safety regulations apply for valves as for the pipe system in which they are installed. The following instructions only include additional safety instructions to be observed for valves.

When using this valve, the generally recognized rules of good practice (standards, DVGW regulations W 332 and W 392, VDI guidelines or other regulations valid at the place of installation) must be observed.

2.2. User safety instructions

The operator of the valve must ensure that the valve is only used in accordance with the intended use. This is not the responsibility of the manufacturer. The valve may only be operated by properly qualified and trained staff. The operating manual and the corresponding safety instructions must be read and understood.



It is prohibited to use any valves with a nominal pressure ("PN") and maximum admissible operating temperature insufficient for the operating conditions. The approved range is indicated on the valve.



Warning: Temperatures below 10 °C and above 40° C during work on the pipeline parts involve the risk of injury. Protective measures must be taken accordingly.



Operating media must correspond to the specification of the valve. The manufacturer does not assume any liability for damage resulting from corrosion caused by aggressive media. Neglect of these regulations may result in imminent danger to life and health, and may cause damage to the pipeline.

- The valve must be professionally installed into the pipeline.
- Following EN 1074-1, the maximum flow velocity may not surpass 4 m/s in continuous operation.
- Operating conditions such as vibrations, water impact, erosion, cavitation and major proportions of solid matter in the medium - especially of an abrasive nature – must be clarified with the manufacturer prior to commissioning.

2.3. Special risks



Be sure to free the pipeline from any pressure and risk prior to disassembly, maintenance and repair of the valve. During disassembly the medium may leak, therefore the pipeline and the valve must be completely emptied.

The energy supply must be switched off.



For valves that are used as end valves, the free connection must be shut off or the valve locked securely in the position "shut". **Danger of Crushing!**

3. Transport and storage

All valves must be carefully transported and stored.



The valves are fully enameled or powder-coated. The coatings are shock-sensitive and must be protected against impact stress.



The gaskets are sensitive to light: Unpackaged valves may only be exposed to bright daylight or ultraviolet light for a very short time. This is why the openings are sealed with protective caps. Valves must be stored in darkened rooms, in their original packaging with the protective caps.



In the event of storage over an extended period of time, the storage location should be frost-protected, cool, dry, dark and free of dust. Alternatively, the valves may also be packed in order to fulfill these conditions.

The valve should be stored on a pallet or similar support and only transported with suitable tools such as wide straps to its designated point of installation. Do not use chains!

4. Installation into the pipeline

For the installation of valves into pipe systems, the same instructions apply as for the connection of pipe system components. The following work steps must be observed:

- Gaskets must be suitable for the flange shape, the operating medium and the nominal pressure in question.
- In case of flanges with smooth sealing surfaces we recommend preferably flange gaskets with steel core as per EN 1514 part 1.
- Transport the valve to the point of installation in its protective packaging.
- Remove all packaging materials from the valve.
- Check valve for transportation damage. Damaged valves must not be installed
- Check coating for damages. The coating may be mended with a repair kit.
- It needs to be ensured that nominal pressure and connecting dimensions of the valves are in correspondence with the operating conditions. See marking on the valve.
- Remove dirt and hard foreign matter from valves and pipelines prior to installation.
- A functional test must be carried out prior to installation: The valve must shut and open properly.
- The connections of the pipeline must be adjusted concentric, and with flanges, plane parallel to the valve.

- When inserting the valve and the gaskets into a pipe already mounted, the gap between the pipe ends must be large enough, so that none of the connecting faces and gaskets are damaged. The gap should not be larger than absolutely necessary so as not to create any additional tension inside the pipe during installation.
- Shut- off valves may be installed in any installation position independent of the flow direction.
- On the tapping valve, turn the sealing wedge to the “open” position prior to the welding process on the PE pipes.
- Dueker PE- HD tapping valves are equally suitable for electro socket fusion and hot plate welding.
- The welding process must be carried out in line with the guidelines and instructions of the welding apparatus and valve manufacturers.
- The valve must be welded in free of tension.
- In addition, all guidelines in line with DVS 2207 and DVGW G 472 are to be observed.
- When using detergents and disinfectants it must be ensured that these products do not attack the materials and gaskets of the valve.
- Newly installed pipe systems must be flushed thoroughly in order to remove all foreign particles.
- During the pressure test of the pipe system with the installed valve, the following test pressures may not be surpassed:



Valve opened: The test pressure must not exceed $1.5 \times PN$ (see type plate).
Valve shut: The test pressure must not exceed $1.1 \times PN$ (see type plate).

- The valve must be protected from dirt which can derive from work (e.g. painting, masonry and concrete work) in the area of the valve.

5. Operation

The valve is shut by turning it clockwise and is opened by turning it in the opposite direction. Manual power suffices to operate the valves. Use of extensions to increase actuating torque is not permissible, since this will cause damage to the valve.

nominal diameter DN	max. operating torque as per EN 1074-2 MOT Nm	no. of turns for closing	stem square mm
40	40	10	12
50	50	12,5	12

Operating torques

The stated operating torques are the maximum permissible torques for full differential pressure at the actuating stem, these are described in EN 1074-2.

6. Actuators

The Service connection valves type 1004 with welding studs PE are available with hand wheel and stem extension set.

7. Inspection and Maintenance

The valves do not require regular maintenance work. However, when a pipeline section is inspected, the valve may not show any leakage to the outside.

The valve should be checked for tightness and, proper function at least once per year (DVGW datasheet W 392-2 and W 400-3-B1).

8. Drawing and parts list

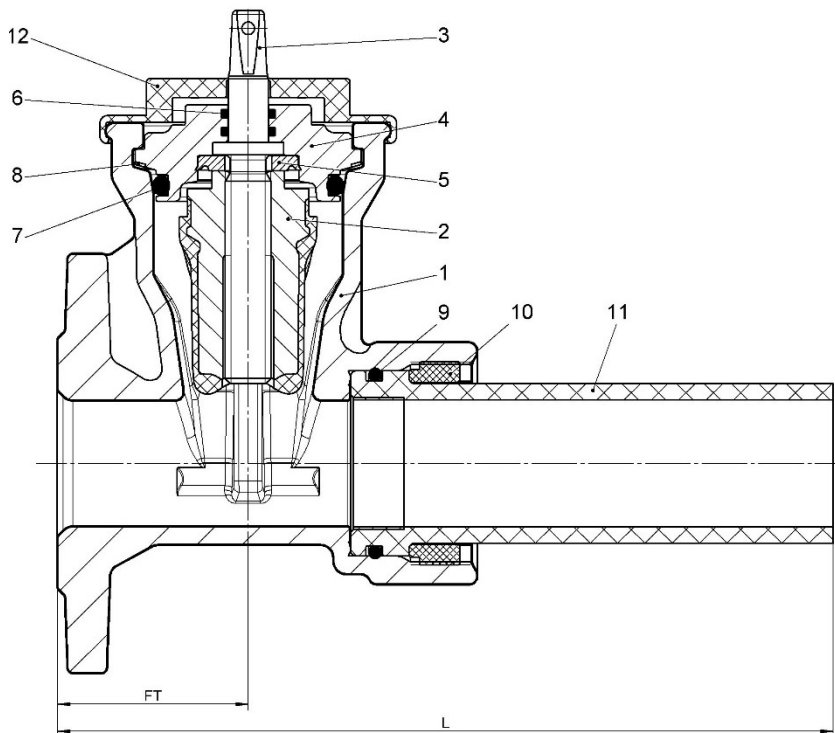

Pos	Description
1	Body
2	Obturator
3	Stem
4	Bajonet nut connector
5	Clamping disk
6	O-Ring
7	O-Ring
8	Slide washer
9	O-Ring
10	Ring nut
11	Transition piece
12	Adapter cap

All spare parts are available as a complete package “bonnet complete with stem”, except Pos. 1, 9, 10, 11, 12.

Dimensions type 1004

DN	L	FT
40	280	70
50	305	75

9. Diagnostics and trouble shooting

Problem	Possible cause	Remedial action
Gate valve does not close	Foreign particle on sealing face	Remove foreign particle
	Heavy deposits on the sliding surface	Clean sliding surface
Gate valve does not open	Foreign particle is jamming sealing wedge	Remove foreign particle

Leakage at the stem or seat gasket:

- Check whether the valve is completely shut.
- If so: Verify whether the valve has been shut with the full torque.
- If leakage on the valve continues: Open and shut the valve several times while under pressure.
- If the leakage on the valve continues: Repair necessary.
- Replace the bonnet unit with sealing wedge and head gasket following consultation with the manufacturer.



We would like to point out that we do not assume any liability for damages or disruption of operations resulting from non- observance of the operating manual.

To ensure the function and compliance with the drinking water hygiene standards, only original Düker original spare parts may be installed.

The distribution and reproduction of these Operating Instructions, utilization and communication of their contents to others is authorized exclusively for the purpose of ensuring the correct installation and operation of the Düker product treated in the document. For all other purposes, distribution, reproduction and utilization of the contents, also in excerpts, is prohibited. Offenders will be held liable for the payment of damages. All rights reserved in the event of the grant of a patent, utility model or design.